

gForce IR

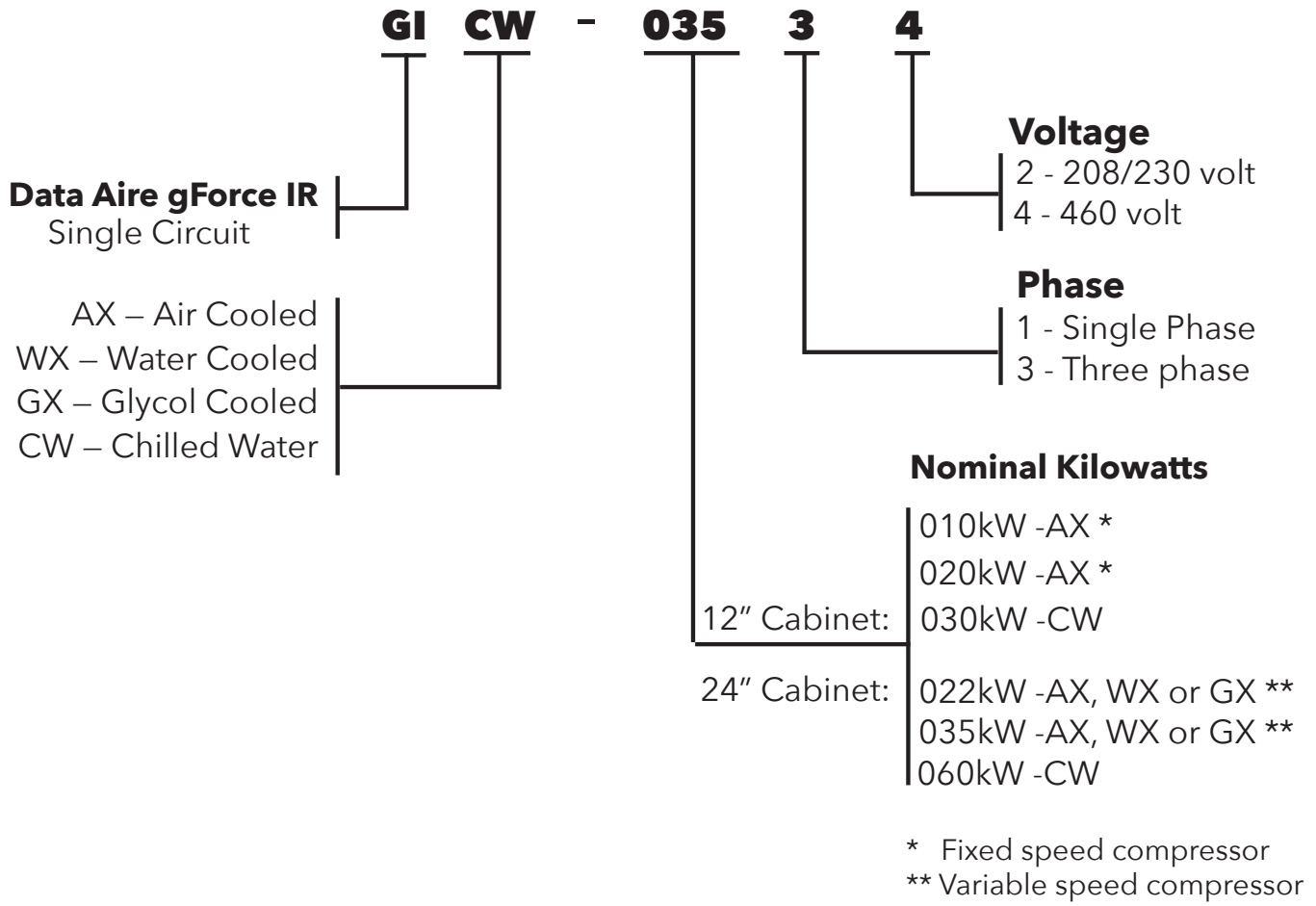

Model Number Identification





Building on more than 50 years of experience, Data Aire produces innovative solutions to meet the developing demands of critical spaces. We are a solutions-driven organization with a passion for finding creative answers by working with our customers through a consultative process.

Known for products that are designed utilizing high levels of technology, Data Aire engineers are experienced visionaries who adapt processes and design proprietary unit enhancements which reflect the constant needs of today's mission critical spaces.

Data Aire combines extensive expertise in control logic with world-class manufacturing capability recognized by key international quality certifications. For those seeking reliable, scalable, customized technology, we provide the solutions of choice. Our precision air control equipment and intelligent energy management technology serve customers in diverse applications worldwide.

gForce IR: Direct Rack Cooling In Any Direction

The direct expansion (DX) or chilled water (CW) gForce IR is a precision row-based cooling unit designed to be installed within high-density server racks that are placed in a hot aisle/cold aisle design. The air enters the unit from the rear (hot aisle) and is discharged from the front (cold aisle). For precise cooling and optimal flexibility, gForce IR units have field-adjustable air delivery diffusers located in the discharge air stream to customize airflow direction. Adjustments allow for right, left or straight ahead air discharge.

Available in two widths for flexibility

- 12" (12"w x 42"d x 78.5" h)
- 24" (24"w x 42"d x 78.5" h)



FEATURES

dap4 Microprocessor

High-quality microprocessor to control and monitor the operation of the gForce IR. Equipped with LCD screen to clearly display the unit's functionality.

Targeted, Precise Cooling

Directs air where it needs to be via the Coanda effect for directional adjustment.

Variable Speed

- Adjustable variable speed fans for optimal efficiency
- Variable speed compressor provides substantial variable capacity modulation to accurately match varying temperature demands, resulting in increased energy savings.

Intelligent Controls

SMART SYSTEM CONTROLS FOR MISSION CRITICAL ENVIRONMENTS

Incorporating advances based on years of control-logic experience, Data Aire system control products offer maximum operational flexibility and growth potential. From a versatile microprocessor controller or a dependable relay autochangeover unit, to accessories that help prevent hot spots in rack installations and compensate for short-term power outages, Data Aire technology keeps you in command.

The gForce systems come equipped with dap4 touch for the dap4 control panel. dap4 supports the following network protocols for integration with a Building Management System (BMS) for Computer Room Air Conditioning (CRAC) system monitoring and control: Modbus RTU, TCP/IP, SNMP V1 or V2, BACnet IP or MS/TP and LonTalk SNVT. Building Management System Interface: Unit(s) shall be furnished with an optional interface card to communicate directly with the Building Automation System (BAS) through a RS-485, Ethernet or LonTalk port. All alarms, set points, and operating parameters that are accessible from the unit mounted control panel shall also be made available through the BAS.

CONTROLS

AUTOMATIC CONTROL FUNCTIONS

- Humidity Anticipation
- Auxiliary Chilled Water Operation*
- Sequential Load Activation
- Start Time Delay
- Automatic Reheat Element Rotation
- Temperature Anticipation
- Energy Saver (Glycol Operation)*
- Hot Water Coil Flush Cycle*
- Dehumidification Lockout
- Chilled Water Coil Flush Cycle*
- Energy Saver Coil Flush Cycle*
- Selectable Water Under Floor Alarm Action
- Compressor Short Cycle

CONDITION AND DATA ROUTINELY DISPLAYED

- Current Date and Time
- Unit Status
- Temperature Setpoint
- Humidity Setpoint
- Current Temperature
- Cooling 1, 2, 3, 4*
- Current Humidity
- Dehumidification
- Humidification
- Current Fan Speed*
- Reheat Stages
- Discharge Temperature*

SWITCHING AND CONTROL FUNCTIONS

- System On/Off/Esc Button
- Menu Selection Buttons
- Menu Exit Button
- Select Buttons
- Alarm Silence Button
- Program Set Button
- Manual Override for:
 - Cool 1, Cool 2, Heat 1, Humidification, CW Valve and Fan Speed

ALARMS

- High Temperature Warning
- Low Temperature Warning
- Low Pressure Compressor 1
- High Pressure Compressor 1
- Dirty Filter
- Firestat Tripped
- Temperature Sensor Error
- No Water Flow*
- Fan Motor Overload*

- High Humidity Warning
- Low Humidity Warning
- Low Pressure Compressor 2
- High Pressure Compressor 2
- Under Floor Water Detection
- Compressor Short Cycle
- Humidity Sensor Error
- Smoke Detector*
- Standby Pump On*

- Local Alarm
- Manual Override
- Humidifier Problem
- Custom Message*
- Power Failure Restart
- Maintenance Required
- Discharge Sensor Error*
- High Condensate Water Level*
- Person to Contact on Alarm*

HISTORICAL DATA

High Temperature Last 24 Hours
High Humidity Last 24 Hours
Alarm History (Last 100 Alarms)
Equipment Runtimes for:
Blower, Compressor 1, Compressor 2, Reheat 1, 2, 3, Dehumidification,
Energy Saver*, Humidifier, Condenser and Chilled Water

Low Temperature Last 24 Hours
Low Humidity Last 24 Hours
Hourly Average of Duty

PROGRAMMABLE FUNCTIONS

Temperature Setpoint	Temperature Deadband	Fan Control Mode
System Start Delay	Low Temperature Alarm Limit	Humidity Deadband
Humidity Setpoint	High Humidity Alarm Limit	Low Humidity Alarm Limit
Define Password	Reset Equipment Runtimes	Audio Alarm Mode
Compressor Short Cycle Alarm	Humidity Anticipation	Compressors(s)
Analog Module Sensor Setup*	Calibrate Temperature Sensor	Temperature Scale
High Temperature Alarm Limit	Fan Speed Settings	Delay for Optional Alarm 1, 2, 3, 4
Firestat Temperature Alarm Limit	Manual Diagnosis	Remote Alarm 1, 2, 3, 4 Selection
Calibrate Discharge Air Sensor*	Person to contact on Alarm	Compressor Lead/Lag Sequence
Dehumidification Mode	Humidifier Autoflush Timer*	Power Problem or Restart Mode
Scheduled Normal Maintenance	Reheat Stages	Water Valve Mode
Calibrate Humidity	Humidifier	Network Protocol
Compressor Supplements to Energy Saver*		
Low Discharge Temperature Alarm Limit*		
Calibrate Chilled Water Temperature Sensor*		

ACCESSORIES

RackSense 32
dap4 Smart Power Capacitor
dap4 Power Meter

* Optional: Some of the programmable selections, displays or alarms may require additional components or sensors.

Models & Capacities

GIXX-022XX @ 2500 CFM (24" Cabinet)

EAT °F (DB/WB)	Air Cooled		Glycol Cooled		Water Cooled	
	Net Total kW (BTU/hr)	Net Sensible kW (BTU/hr)	Net Total kW (BTU/hr)	Net Sensible kW (BTU/hr)	Net Total kW (BTU/hr)	Net Sensible kW (BTU/hr)
72/58.6	15.4 (52,600)	13.0 (44,500)	14.9 (50,700)	12.9 (44,000)	17.1 (58,400)	13.9 (47,300)
75/61	16.4 (56,000)	13.4 (45,600)	15.9 (54,100)	13.2 (45,100)	18.2 (62,000)	14.2 (48,500)
72/60	16.1 (55,000)	11.8 (40,400)	15.5 (53,000)	11.7 (40,000)	17.9 (61,100)	12.6 (43,000)
75/62.5	17.1 (58,400)	12.1 (41,300)	16.5 (56,400)	12.0 (41,000)	18.9 (64,600)	12.9 (44,000)
80/67	18.7 (63,900)	12.6 (43,000)	18.2 (62,100)	12.5 (42,800)	20.7 (70,500)	13.5 (45,900)

GIXX-035XX @ 3600 CFM (24" Cabinet)

EAT °F (DB/WB)	Air Cooled		Glycol Cooled		Water Cooled	
	Net Total kW (BTU/hr)	Net Sensible kW (BTU/hr)	Net Total kW (BTU/hr)	Net Sensible kW (BTU/hr)	Net Total kW (BTU/hr)	Net Sensible kW (BTU/hr)
72/58.6	28.9 (98,700)	22.9 (78,000)	27.8 (94,700)	22.6 (77,200)	30.9 (105,600)	23.9 (81,500)
75/61	30.6 (104,300)	23.4 (80,000)	28.5 (97,400)	22.5 (76,700)	33.4 (113,800)	25.2 (86,000)
72/60	30.2 (102,900)	21.2 (72,400)	28.2 (96,100)	20.2 (68,800)	32.2 (109,900)	22.3 (76,100)
75/62.5	31.7 (10,8300)	21.8 (74,300)	29.7 (101,300)	20.7 (70,800)	33.8 (115,500)	22.9 (78,100)
80/67	34.4 (117,500)	22.7 (77,600)	32.2 (109,800)	21.7 (74,000)	36.6 (125,000)	23.8 (81,200)

GIXX-XXXXX-AO (12" Cabinet)

EAT °F (DB/WB)	GIAX-010XX-AO @ 2,300 CFM		GIAX-020XX-AO @ 2,700 CFM		Net Total kW (BTU/hr)	Net Sensible kW (BTU/hr)
	Net Total kW (BTU/hr)	Net Sensible kW (BTU/hr)	Net Total kW (BTU/hr)	Net Sensible kW (BTU/hr)		
72/58.6	7.9 (27,100)	7.9 (27,100)	16.8 (57,200)	15.4 (52,700)	-	-
75/61	8.4 (28,600)	8.3 (28,300)	17.7 (60,300)	15.7 (53,700)	-	-
72/60	8.1 (27,700)	7.9 (27,100)	17.4 (59,500)	14.4 (49,000)	-	-
75/62.5	8.6 (29,400)	8.1 (27,600)	18.3 (62,500)	14.7 (50,100)	-	-
80/67	9.4 (32,000)	8.4 (28,600)	19.8 (67,500)	15.2 (52,000)	-	-

GICW-XXXXX						
	GICW-030XX (12" Cabinet) @ 3,000 CFM, 8 GPM		GICW-060XX (24" Cabinet) @ 4,600 CFM, 17 GPM			
EAT °F (DB/WB)	Net Total kW (BTU/hr)	Net Sensible kW (BTU/hr)	Net Total kW (BTU/hr)	Net Sensible kW (BTU/hr)	Net Total kW (BTU/hr)	Net Sensible kW (BTU/hr)
72/58.6	11.8 (40,300)	11.8 (40,300)	21.9 (74,700)	21.8 (74,500)	-	-
75/61	13.2 (45,200)	13.2 (45,200)	25.5 (86,900)	24.3 (83,000)	-	-
72/60	11.8 (40,300)	11.8 (40,300)	22.4 (76,600)	20.9 (71,200)	-	-
75/62.5	13.4 (45,700)	13.0 (44,400)	26.5 (90,400)	22.9 (78,100)	-	-
80/67	16.4 (56,000)	14.6 (49,700)	34.2 (116,600)	25.6 (87,300)	-	-

GIXX-XXXXX @ STANDARD AIRFLOW						
	EC Plug Fans			Dimensions		
Capacity, kW	Number of Fans	Standard Fan Size, mm	Standard Fan Motor, kW	Depth, in.	Width, in.	Height, in.
10	5	200	0.17	42.0	12.0	78.5
20	6	200	0.17	42.0	12.0	78.5
22	2	315	2.2	42.0	24.0	78.5
35	2	315	2.2	42.0	24.0	78.5
30	6	200	0.17	42.0	12.0	78.5
60	3	315	2.2	42.0	24.0	78.5

1. Performance data is based on ACFM and tested in compliance with ASHRAE Standard 127-2007 Standard Rating Conditions.
2. Net capacity data includes fan motor heat.
3. Models with an AO suffix are configurations with the compressor located in outdoor condensing unit.
4. Consult factory for alternate operating conditions or options as these may impact unit performance.
5. Performance data based on an entering chilled water temperature of 45°F.

www.DataAire.com
800-347-2473 | sales@DataAire.com
230 W. Blueridge Avenue
Orange, CA 92865



A member of the
C/S Group of Companies
Making Building Better®