

**gForce**



**R-410A and R-407C**

Dual Circuits | Air, Water/Glycol Cooled | 21 to 106 kW



# Model Number Identification

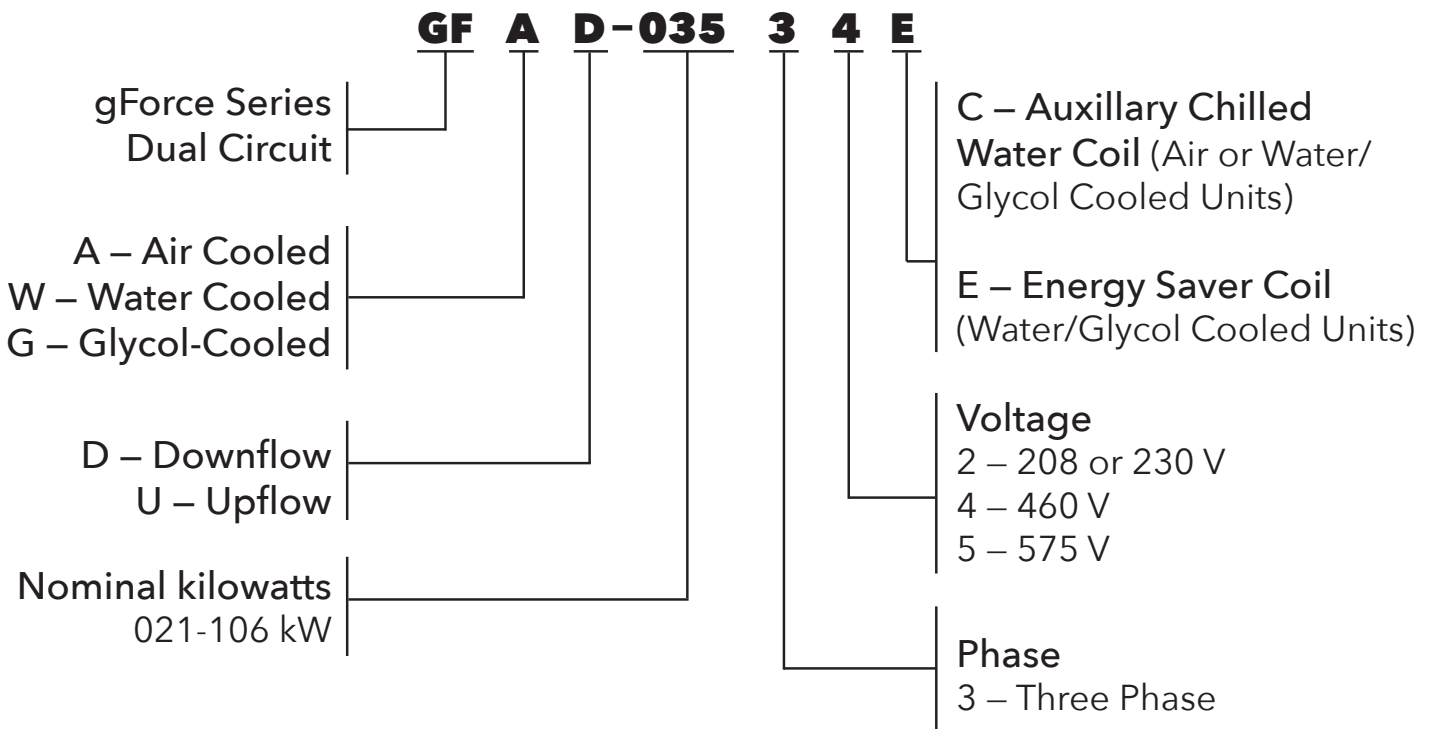



Building on more than 50 years of experience, Data Aire produces innovative solutions to meet the developing demands of critical spaces. We are a solutions-driven organization with a passion for finding creative answers by working with our customers through a consultative process.

Known for products that are designed utilizing high levels of technology, Data Aire engineers are experienced visionaries who adapt processes and design proprietary unit enhancements which reflect the constant needs of today's mission critical spaces.

Data Aire combines extensive expertise in control logic with world-class manufacturing capability recognized by key international quality certifications. For those seeking reliable, scalable, customized technology, we provide the solutions of choice. Our precision air control equipment and intelligent energy management technology serve customers in diverse applications worldwide.

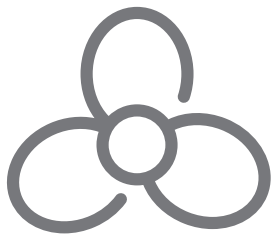

## MISSION CRITICAL COOLING

gForce by Data Aire are efficient and economical while complying with strict environmental requirements. Incorporating backward curved plenum fans with electronically commutated (EC) motors, these units supply radially dispersed cooling air at lower speeds allowing for more uniform static pressure across the room. These fans provide more net cooling from the computer room air conditioning (CRAC) system. DC motors are more energy efficient, providing an on-going savings year after year. Each unit is factory run tested and put through a vigorous quality control procedure.



## DATA AIRE DELIVERS

Standard lead time for a standard unit is 30 days from date of order. With an optional premium "quick ship" units can be expedited to ship in as little as one week. All units are built to your specific order and specification. Not only does Data Aire deliver standard products in short lead times, our consultative process helps you meet your specific requirements.



## THERMODYNAMIC ENERGY EFFICIENCIES

The gForce design incorporates rifled tubing cooling coils which force the refrigerant gas and liquid to rotate as it passes through the coil. The coldest refrigerant is in contact with warmest surface resulting in better heat transfer.



### IMPROVED PERFORMANCE AND REDUCED MAINTENANCE

Backward curved fans discharge air radially, allowing for uniform static pressure across the raised floor. Traditional forward curved fans prohibit optimal airflow through the raised floor close to the CRAC. One of the key features of backward curved fans, commonly referred to as plug fans, is that the motor and fan are integrated into a single unit, and includes a separate speed controller. This eliminates the need for monthly maintenance, belt replacement and all belt dust.

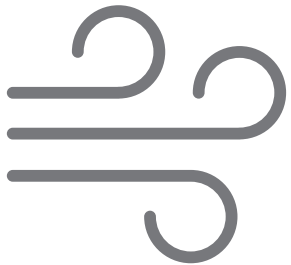

### IMPROVED AIRFLOW DESIGN

The increased capacity of the gForce internal cabinet allows for less restrictive airflow. When additional options are added to smaller cabinets, the static pressure within the unit increases, making airflow more difficult. The advanced design of the bigger interior and the product's quality construction ensures the highest level of efficiency in a precision air system.



### ENVIRONMENTALLY RESPONSIBLE

The R-407C or R-410A refrigerants comply with the requirements of the Montreal Protocol which called for the phase out of refrigerants that deplete the ozone layer.

# Design Features

## DESIGN

gForce units feature a specially designed compact tubular steel frame which allows for minimum space requirement of air conditioning equipment in the controlled area. Although compact, all parts are easily accessible providing excellent serviceability. The heart of the system is the Data Alarm Processor (dap4), a microprocessor based controller. The dap4 not only controls and monitors temperature, humidity, airflow, and cleanliness, it provides component runtimes, alarm history, and automatic self-test.

## FRAME AND CABINET

The heliarc welded tubular steel frame provides for maximum strength and ease of access. Side and front doors can be easily opened and removed with quarter-turn fasteners allowing full access to all unit components. All doors include one inch thick, 1-1/2 pound density insulation for thermal performance, protection, and sound attenuation.

## COIL SECTION

Designed for draw-through application, the computer-selected, rifle-tubbing dual circuited A-frame coil has an interwoven surface that increases unit efficiency at low load conditions. Air is drawn through both circuits of the coil at low velocity providing effective surface exposure with minimum turbulence. The coil sits in a stainless steel drain pan.

## FAN SECTION

Backward curved plenum fans with electronically commutated motors are used to provide the most efficient fan/motor combination available in the market today. Electronically commutated motors are DC motors connected to standard AC power. DC motors are more efficient than AC motors and can be programmed to run at various speeds. With the fan blades directly connected to the motor, there is no need for periodic maintenance. In the unlikely event of a fan failure, replacement is simple; remove four bolts, disconnect the power and remove the fan. Reverse the process for installation of a new fan.

## ELECTRIC REHEAT

Low-watt density finned tubular sheathed elements provide ample capacity to maintain room dry bulb conditions during a call for dehumidification. Three stages of reheat are standard.

## HUMIDIFICATION

gForce includes an electric steam generator humidifier with "quick change" disposable cylinders and an auto-flush cycle. The steam generator humidifier, with its patented control system, optimizes cylinder life and energy efficiency by concentrating incoming water to a predetermined conductivity much higher than that of any entering water. The control system continuously monitors the conductivity in the cylinder through its electronics, which allows water to be flushed as often as is necessary to maintain the capacity at this design conductivity. The high design conductivity results in a minimum flushing of heated water, which saves energy. The humidifier is designed to allow all units at any voltage to produce full rated steam output capacity at an optimum low water level based on this design conductivity.

## FILTER SECTION

Units are provided with 4 inch deep, MERV-8 pleated filters. The filter section is accessible from the top, front, or side on downflow units, and the front and right hand side on upflow units.

## REFRIGERATION CIRCUITS

Dual refrigeration circuits include high efficiency hermetic scroll type compressors. Scroll compressors represent proven compressor technology. Scroll compressors offer a combination of reliability, performance, and efficiency. System noise is inherently quieter with scroll compressors.

### SCROLL COMPRESSORS OFFER:

**Simplicity** - Fewer parts. Two components, a fixed scroll and orbiting scroll, replace approximately 15 parts required to do the same work.

**Improved Starting Ability** - With the scroll design the internal compression components always start unloaded even if the system pressures are not balanced. Since internal compressor pressures are always balanced at start-up, low voltage characteristics are excellent for scroll compressors.

**Energy Efficiency** - Scroll compressors are at least 10% more efficient than reciprocating type compressors.

The suction and discharge processes of a scroll compressor are physically separated. This reduces heat transfer between the suction and discharge gas. In a piston type compressor the cylinder is exposed to both suction and discharge gas. This results in high heat transfer reducing the compressor efficiency.

Scroll compressor compression and discharge processes are very smooth. Gas is compressed in approximately 1 1/2 revolutions compared to less than 1/2 revolution for a piston.

Scrolls require no valves. Piston compressors require both suction and discharge valves. No valves, no valve losses.

**Durability** - Significant design effort and system cost are required to protect piston compressors from slugging and debris. Scroll compressors are designed to be more tolerant of both liquid and debris.

**Reliability** - Scrolls contain fewer moving parts, resulting in greater reliability. Proven performance means fewer maintenance calls for field personnel.

**Lower Sound** - Systems properly designed with scroll compressors will be inherently quieter. On average, the compressor is up to 5 decibels quieter. Sound characteristics of a scroll compressor are different than that of a reciprocating compressor. These do not effect system performance or reliability.

These durable, heavy duty compressors have no gaskets or seals, eliminating the possibility of refrigerant or oil leaking into the controlled space or environment. Each refrigeration circuit includes built-in compressor overload protection, crankcase heater, coils, filter drier, sight glass, adjustable expansion valve with external equalizer, and low pressure override timer (air cooled units)

# Refrigeration Circuits

## **AIR COOLED WITH REMOTE OUTDOOR AIR COOLED CONDENSER**

A wide range of outdoor condensers are available with vertical air discharge. Condensers manufactured by Data Aire are sized to meet the required heat rejection and ambient conditions. The industrial duty condenser design includes an aluminum housing, aluminum-finned copper tube coils, powder-coated fan guards, and energy efficient, thermally protected axial-type EC fans. Variable speed axial-type fans allow for control down to 0° F, or -30° F when a low ambient receiver package is selected.

## **AIR COOLED WITH INDOOR CONDENSER**

A wide range of floor mounted indoor condensers with horizontal intake and discharge are available for applications where an outdoor condenser cannot be used. Finished to match the indoor evaporator section, indoor condensers are provided with a factory mounted and piped receiver. The receiver has a head pressure control valve to maintain flooded condenser control.

## **AIR COOLED WITH REMOTE OUTDOOR CONDENSING UNIT**

When compressors are required to be out of the controlled space, Data Aire Series units are available with a remote outdoor condensing unit. The condensing unit includes the compressors with built-in overload protection, crankcase heater, and condenser coil. The condenser coil is constructed with copper tubes and aluminum fins. The housing is aluminum with vertical air discharge. Variable speed axial-type fans allow for control down to 0° F, or -30° F when a low ambient receiver package is selected.

## **WATER/GLYCOL COOLED INDOOR EVAPORATIVE UNIT**

Water/glycol cooled units include counterflow condensers sized to provide the required capacity for heat rejection with minimum water/glycol flow and total pressure drop. Head pressure regulating valves control the condensing temperature and maintain required capacity at various water/glycol flow rates and temperatures.

## **WATER/GLYCOL COOLED WITH REMOTE OUTDOOR FLUID/DRY COOLER**

Remote outdoor coolers are available in a variety of sizes. Each dry cooler includes an aluminum housing, aluminum-finned copper tube coil, powder-coated fan guards, expansion tank, pump contactor, and energy efficient, thermally protected axial-type EC fans.

## **WATER/GLYCOL COOLED WITH INDOOR FLUID/DRY COOLER**

When required a wide range of floor mounted indoor coolers are available. The air intake and discharge are horizontal. Units are finished to match the indoor unit. The unit control panel includes a pump contactor (units can be ordered with a factory mounted pump).



## SMART SYSTEM CONTROLS FOR MISSION CRITICAL ENVIRONMENTS

Incorporating advances based on years of control-logic experience, Data Aire system control products offer maximum operational flexibility and growth potential. From a versatile microprocessor controller or a dependable relay autochangeover unit, to accessories that help prevent hot spots in rack installations and compensate for short-term power outages, Data Aire technology keeps you in command.

The gForce systems come equipped with dap4 touch for the dap4 control panel. dap4 supports the following network protocols for integration with a Building Management System (BMS) for Computer Room Air Conditioning (CRAC) system monitoring and control: Modbus RTU, TCP/IP, SNMP V1 or V2, BACnet IP or MS/TP and LonTalk SNVT. Building Management System Interface: Unit(s) shall be furnished with an optional interface card to communicate directly with the Building Automation System (BAS) through a RS-485, Ethernet or LonTalk port. All alarms, set points, and operating parameters that are accessible from the unit mounted control panel shall also be made available through the BAS.

## CONTROLS

AUTOMATIC CONTROL FUNCTIONS	CONDITION AND DATA ROUTINELY DISPLAYED	SWITCHING AND CONTROL FUNCTIONS
Humidity Anticipation Auxiliary Chilled Water Operation* Sequential Load Activation Start Time Delay Automatic Reheat Element Rotation Temperature Anticipation Energy Saver (Glycol Operation)* Hot Water Coil Flush Cycle* Dehumidification Lockout Chilled Water Coil Flush Cycle* Energy Saver Coil Flush Cycle* Selectable Water Under Floor Alarm Action Compressor Short Cycle	Current Date and Time Unit Status Temperature Setpoint Humidity Setpoint Current Temperature Cooling 1, 2, 3, 4* Current Humidity Dehumidification Humidification Current Fan Speed* Reheat Stages Discharge Temperature*	System On/Off/Esc Button Menu Selection Buttons Menu Exit Button Select Buttons Alarm Silence Button Program Set Button Manual Override for: Cool 1, Cool 2, Heat 1, Humidification, CW Valve and Fan Speed

## ALARMS

High Temperature Warning Low Temperature Warning Low Pressure Compressor 1 High Pressure Compressor 1 Dirty Filter Firestat Tripped Temperature Sensor Error No Water Flow* Fan Motor Overload*	High Humidity Warning Low Humidity Warning Low Pressure Compressor 2 High Pressure Compressor 2 Under Floor Water Detection Compressor Short Cycle Humidity Sensor Error Smoke Detector* Standby Pump On*	Local Alarm Manual Override Humidifier Problem Custom Message* Power Failure Restart Maintenance Required Discharge Sensor Error* High Condensate Water Level* Person to Contact on Alarm*
---	---	--

# Intelligent Controls

## HISTORICAL DATA

High Temperature Last 24 Hours  
High Humidity Last 24 Hours  
Alarm History (Last 100 Alarms)  
Equipment Runtimes for:  
Blower, Compressor 1, Compressor 2, Reheat 1, 2, 3, Dehumidification,  
Energy Saver\*, Humidifier, Condenser and Chilled Water

Low Temperature Last 24 Hours  
Low Humidity Last 24 Hours  
Hourly Average of Duty

## PROGRAMMABLE FUNCTIONS

Temperature Setpoint	Temperature Deadband	Fan Control Mode
System Start Delay	Low Temperature Alarm Limit	Humidity Deadband
Humidity Setpoint	High Humidity Alarm Limit	Low Humidity Alarm Limit
Define Password	Reset Equipment Runtimes	Audio Alarm Mode
Compressor Short Cycle Alarm	Humidity Anticipation Compressors(s)	Analog Module Sensor Setup*
Calibrate Temperature Sensor	Temperature Scale	High Temperature Alarm Limit
Fan Speed Settings	Delay for Optional Alarm 1, 2, 3, 4	Firestat Temperature Alarm Limit
Manual Diagnosis	Remote Alarm 1, 2, 3, 4 Selection	Calibrate Discharge Air Sensor*
Person to contact on Alarm	Compressor Lead/Lag Sequence	Dehumidification Mode
Humidifier Autoflush Timer*	Power Problem or Restart Mode	Scheduled Normal Maintenance
Reheat Stages	Water Valve Mode	Calibrate Humidity
Humidifier	Network Protocol	
Compressor Supplements to Energy Saver*		
Low Discharge Temperature Alarm Limit*		
Calibrate Chilled Water Temperature Sensor*		

## ACCESSORIES

RackSense 32  
dap4 Smart Power Capacitor  
dap4 Power Meter

\* Optional: Some of the programmable selections, displays or alarms may require additional components or sensors.

## **ENERGY SAVER COIL**

The Data Aire Energy Saver Coil is built into the system to provide total required capacity. Whenever the incoming water/glycol temperature is below the setpoint of the water changeover thermostat, Energy Saver cooling is available. Energy Saver mode operates in the following range: Return air setpoint plus deadband plus two degrees. The Energy Saver will operate providing there is a need for cooling. The valve will open at setpoint plus deadband. The valve will modulate as long as the space is between setpoint plus deadband plus 2 degrees. If the temperature falls below the deadband minus setpoint, the valve will close and the space is considered satisfied. If the temperature goes beyond setpoint plus deadband plus 2 degrees while still in Energy Saver Mode with the valve modulating, the Energy Saver valve will close and DX cooling will begin.

The Energy Saver Coil includes a 3-way modulating pressure control valve on condenser water circuit, and a 3-way modulating valve on the Energy Saver Coil. Common piping for coil and condenser is provided.

## **ENERGY SAVER/COMPRESSOR ASSIST**

Units with the Energy Saver Coil can be provided with compressor assist if the Energy Saver is not sufficient as a stand alone system. When the incoming water/glycol temperature is below the setpoint of the water changeover thermostat, the Energy Saver mode is enabled (even if there is no call for cooling). Upon a call for cooling (setpoint plus deadband), the valve will open proportionally - 10% for each 0.1° above setpoint plus deadband. The compressor will come on at setpoint plus deadband plus 1.0° (the valve is 100% open at this point). The compressor will turn off at setpoint plus deadband plus 0.7°. The valve will close proportionally - 10% for each 0.1° below setpoint plus deadband. An air discharge sensor is factory installed.

## **AUXILIARY CHILLED WATER COIL**

Where an existing chilled water loop is available, units can be fitted with an auxiliary chilled water coil. Units will operate using the chilled water for cooling. Upon a loss of water flow or an increase in room temperature the system will bring on compressor (DX) cooling. Separate piping is provided for the chilled water coil and refrigeration connections.

## **AUXILIARY CHILLED WATER COIL/COMPRESSOR ASSIST**

The Auxiliary Chilled Water Coil can be provided with compressor assist for extended savings by allowing the compressor to supplement operation as needed when the chilled water is not sufficient on a stand alone basis. An discharge air sensor is factory installed.

## **REMOTE TEMPERATURE AND HUMIDITY SENSORS**

Temperature and humidity sensors may be ordered for remote wall mounting in lieu of the standard return air sensors. Sensors are provided in a wall mounted plastic case for remote sensing of temperature and humidity. 35 feet of shielded cable is provided for field wiring. Other lengths available as well.

## **SMOKE DETECTOR**

A unit mounted smoke detector will shut down the unit if smoke is sensed. The microprocessor will sound an alarm and display a "SMOKE DETECTED" message. The smoke detector is mounted in the return air stream and is provided with auxiliary contacts.

## **HOT WATER REHEAT**

Where hot water is available, a unit installed reheat coil can use hot water reheat. The system is designed for 150 psi maximum water pressure and includes a 2-way valve (a 3-way valve is optional).

## **HOT GAS REHEAT**

Unit hot gas discharge is used for reheat and maximum system efficiency.  
(Note: Units with Hot Gas Bypass option are not available with hot gas reheat).

## **UNIT MOUNTED DISCONNECT**

A unit mounted nonautomatic disconnect switch is installed in the high voltage electrical section. The operating mechanism allows access to the high voltage electrical components when switched to the "OFF" position. The operating mechanism (handle) protrudes through the decorative door.

## **HOT GAS BYPASS**

A hot gas bypass valve is available for applications that create low suction pressure conditions that could lead to coil freeze and/or compressor cycling. In facilities, such conditions generally exist in instances where:

- 1) a unit's dehumidification mode needs to run for extended period of time; or
- 2) a room is designed for low entering air conditions; or
- 3) a unit is utilizing an oversized condenser at low outdoor ambient conditions.

When the system suction pressure is high enough it will maintain pressure on the leaving side of the hot gas bypass valve to keep the valve port closed. Should the suction-pressure decrease below the desired setting, the pressure from the suction line forces the diaphragm, which off-sets the spring pressure, allowing the spring to push the valve open. The opening of this valve allows some hot gas to mix with the refrigerant in the suction line raising the evaporator pressure. This increases the suction pressure in the system back to the desired setting. The hot gas bypass can be manually adjusted within a certain range to fine tune the unit to a desired suction pressure in the field.

## **3-WAY WATER REGULATING VALVE**

3-way water regulating valve for pressure control may be ordered to replace standard 2-way valve installed in a water/glycol unit. 3-way valves provide control of condensing temperature, maintaining constant system capacity and condenser water flow.

## **CONDENSATE PUMP**

Condensate pumps may be ordered as factory installed or for field installation. Condensate pumps are complete with sump, motor, and automatic control. The pumps are rated for 145 GPH at 40 feet (460v) or 168 GPM at 40 feet (230v) maximum. Pumps shipped loose are available in 115, 230, or 460 volt.

## **UPFLOW PLENUM**

Upflow plenums are fully insulated with front discharge air grilles. Side grilles for both or one side are available. Standard plenums are 24 inches high and are painted to match the unit color.

## **FLOORSTAND**

Floorstands are adjustable -1/+3 inches and are available with seismic construction.

## **EXTENDED COMPRESSOR WARRANTIES**

Data Aire offers either a two year or a four year extended compressor warranty in addition to the standard 18-month parts warranty. These extended warranties cover parts only (not labor).

## **TANDEM SCROLL COMPRESSORS**

Units may be ordered with tandem scroll compressors when four stage compressor control is required. Units remain dual circuited. Tandem scrolls offer the inherent advantages of scroll technology: higher efficiency, increased reliability, lower sound, and excellent liquid handling.

Tandem scrolls offer four steps of modulation so that one or both compressors (per circuit) can run depending upon the load of the system, resulting in part-load efficiency equal to full load efficiency. Four-step modulation is possible because of a carefully designed tubing configuration and the scroll's superior ability to tolerate liquid. The built-in discharge check valve, present in all tandem scroll compressors, effectively prevents liquid migration in the off compressor. Oil migration is controlled with two specially designed oil and gas equalization lines. Adding this option to 160kW unit will increase cabinet size to 144".

## **HUMIDIFIER MODULATING CONTROL**

Modulating control may be added to the unit's steam generator humidifier. Modulating control will allow the humidifier to match its output to the signal from the humidity control. A self-regulating auto flush is included.

## **HIGH EFFICIENCY FILTERS**

Standard filters are rated MERV 8 based on ASHRAE 52.2. Higher efficiency filters are available (consult factory regarding efficiency percentage and unit static pressures).

# Options

## **PUMP PACKAGE**

Centrifugal pump packages are available to circulate water or water/glycol solutions. Pumps are available in various horsepower and voltages. Both 3400 and 1750 rpm pumps are available as an option. On dual pump applications it is recommended that a 3-way water regulating valve be used in lieu of the standard 2-way valve.

## **PUMP ENCLOSURE**

Pump enclosures are available for either single or dual pump applications. Pump enclosures are vented and weather resistant. When ordered with pumps, the pumps are factory mounted in the enclosure ready for field piping and wiring.

## **INTEGRAL PUMP ENCLOSURES**

Pumps may be factory mounted as an integral part of the fluid/dry cooler. A 30" extension is added to the cooler. Pumps are pre-piped, pre-wired and include shut-off valves. A NEMA 4 switch (field installed) is included with dual pumps.

## **PUMP AUTO-CHANGEOVER**

Dual pump packages may be provided with a pump auto-changeover control and NEMA 4 flow switch (field installed). The pump auto-changeover control is factory wired and mounted in the cooler control. The pump auto-changeover control provides automatic pump changeover in the event of a pump failure. Upon pump changeover, an audible alarm will sound at the indoor unit and a message ("STANDBY PUMP ON") will be displayed on the indoor unit dap controller display.

# Models & Capacities

## GFXX-021XX @ 2700 CFM

EAT °F (DB/WB)	Air Cooled		Glycol Cooled		Water Cooled	
	Net Total kW (BTU/hr)	Net Sensible kW (BTU/hr)	Net Total kW (BTU/hr)	Net Sensible kW (BTU/hr)	Net Total kW (BTU/hr)	Net Sensible kW (BTU/hr)
72/58.6	18.1 (61,700)	15.7 (53,600)	17.4 (59,500)	15.4 (52,700)	20.4 (69,500)	16.7 (57,100)
75/61	18.8 (64,200)	16.2 (55,200)	18.0 (61,500)	15.8 (54,000)	21.3 (72,600)	17.2 (58,800)
72/60	18.5 (63,100)	14.7 (50,200)	17.9 (61,100)	14.5 (49,400)	21.0 (71,500)	15.8 (53,900)
75/62.5	19.4 (66,200)	15.1 (51,400)	18.8 (64,100)	14.8 (50,500)	22.0 (75,000)	16.1 (55,100)
80/67	20.9 (71,300)	15.6 (53,400)	20.3 (69,200)	15.4 (52,500)	23.7 (80,800)	16.7 (57,000)

## GFXX-028XX @ 3600 CFM

EAT °F (DB/WB)	Air Cooled		Glycol Cooled		Water Cooled	
	Net Total kW (BTU/hr)	Net Sensible kW (BTU/hr)	Net Total kW (BTU/hr)	Net Sensible kW (BTU/hr)	Net Total kW (BTU/hr)	Net Sensible kW (BTU/hr)
72/58.6	24.0 (81,800)	21.6 (73,600)	23.2 (79,000)	21.2 (72,400)	27.2 (92,800)	23.1 (78,700)
75/61	25.1 (85,700)	22.3 (76,100)	24.3 (83,000)	22.0 (74,900)	28.6 (97,500)	28.6 (81,300)
72/60	24.7 (84,400)	20.2 (68,900)	23.9 (81,700)	19.8 (67,700)	28.1 (96,000)	21.7 (74,000)
75/62.5	26.1 (89,100)	20.7 (70,800)	25.2 (85,900)	20.4 (69,500)	29.6 (101,000)	22.2 (75,900)
80/67	28.4 (96,900)	21.7 (74,000)	27.3 (93,200)	21.3 (72,600)	32.0 (109,100)	23.1 (78,800)

## GFXX-035XX @ 4500 CFM

EAT °F (DB/WB)	Air Cooled		Glycol Cooled		Water Cooled	
	Net Total kW (BTU/hr)	Net Sensible kW (BTU/hr)	Net Total kW (BTU/hr)	Net Sensible kW (BTU/hr)	Net Total kW (BTU/hr)	Net Sensible kW (BTU/hr)
72/58.6	28.8 (98,400)	27.6 (94,300)	27.9 (95,200)	27.2 (92,800)	32.8 (112,000)	29.4 (100,400)
75/61	30.3 (103,400)	28.6 (97,500)	29.1 (99,300)	28.1 (95,800)	34.6 (117,900)	30.5 (104,000)
72/60	29.8 (101,600)	25.8 (88,100)	28.7 (97,800)	25.3 (86,400)	33.9 (115,600)	27.6 (94,200)
75/62.5	31.3 (106,800)	26.5 (90,400)	30.2 (103,100)	26.1 (88,900)	35.5 (121,300)	28.3 (96,400)
80/67	33.9 (115,600)	27.7 (94,400)	32.8 (111,800)	27.2 (92,900)	38.3 (130,700)	29.4 (100,300)

## GFXX-046XX @ 4800 CFM

EAT °F (DB/WB)	Air Cooled		Glycol Cooled		Water Cooled	
	Net Total kW (BTU/hr)	Net Sensible kW (BTU/hr)	Net Total kW (BTU/hr)	Net Sensible kW (BTU/hr)	Net Total kW (BTU/hr)	Net Sensible kW (BTU/hr)
72/58.6	37.5 (127,800)	32.9 (112,400)	36.4 (124,200)	32.5 (110,800)	42.5 (145,000)	35.3 (120,500)
75/61	39.5 (134,900)	34.2 (116,600)	38.1 (130,000)	33.5 (114,400)	44.4 (151,400)	36.3 (124,000)
72/60	38.6 (131,600)	30.9 (105,500)	37.4 (127,600)	30.4 (103,700)	43.6 (148,900)	33.2 (113,400)
75/62.5	40.7 (138,800)	31.7 (108,300)	39.3 (134,100)	31.2 (106,300)	45.8 (156,400)	34.0 (115,900)
80/67	44.2 (150,700)	33.1 (112,900)	42.5 (145,000)	32.4 (110,600)	49.4 (168,700)	35.2 (120,100)

# Models & Capacities

GFX-056XX @ 6400 CFM						
	Air Cooled		Glycol Cooled		Water Cooled	
EAT °F (DB/WB)	Net Total kW (BTU/hr)	Net Sensible kW (BTU/hr)	Net Total kW (BTU/hr)	Net Sensible kW (BTU/hr)	Net Total kW (BTU/hr)	Net Sensible kW (BTU/hr)
72/58.6	46.5 (162,100)	40.3 (137,600)	46.0 (156,800)	39.6 (135,200)	53.4 (182,100)	43.1 (147,100)
75/61	49.9 (170,200)	41.7 (142,300)	48.1 (164,000)	40.9 (139,600)	55.9 (190,700)	44.4 (151,600)
72/60	48.9 (167,000)	37.8 (129,100)	47.2 (161,000)	37.0 (126,400)	54.7 (186,700)	40.4 (138,000)
75/62.5	51.6 (176,000)	38.8 (132,300)	49.8 (169,800)	38.0 (129,700)	57.6 (196,700)	41.4 (141,300)
80/67	56.0 (191,000)	40.3 (137,600)	54.1 (184,500)	39.6 (135,200)	62.6 (213,600)	43.1 (146,900)

GFX-070XX @ 8000 CFM						
	Air Cooled		Glycol Cooled		Water Cooled	
EAT °F (DB/WB)	Net Total kW (BTU/hr)	Net Sensible kW (BTU/hr)	Net Total kW (BTU/hr)	Net Sensible kW (BTU/hr)	Net Total kW (BTU/hr)	Net Sensible kW (BTU/hr)
72/58.6	60.1 (205,100)	53.0 (180,700)	57.5 (196,300)	51.8 (176,800)	68.1 (232,400)	56.7 (193,500)
75/61	63.1 (215,400)	54.8 (187,000)	60.6 (206,700)	53.7 (183,100)	71.5 (243,900)	58.5 (199,600)
72/60	61.6 (210,200)	49.5 (169,000)	59.5 (203,100)	48.6 (165,900)	70.1 (239,300)	53.4 (182,200)
75/62.5	64.9 (221,600)	50.8 (173,400)	62.8 (214,200)	49.9 (170,300)	73.6 (251,300)	54.6 (186,200)
80/67	70.5 (240,700)	53.0 (180,900)	68.1 (232,500)	52.1 (177,700)	79.6 (271,500)	56.6 (193,200)

GFX-091XX @ 9000 CFM						
	Air Cooled		Glycol Cooled		Water Cooled	
EAT °F (DB/WB)	Net Total BTU/hr	Net Sensible BTU/hr	Net Total BTU/hr	Net Sensible BTU/hr	Net Total BTU/hr	Net Sensible BTU/hr
72/58.6	75.3 (257,100)	64.2 (218,900)	72.8 (248,500)	63.0 (215,000)	84.4 (288,000)	68.5 (233,700)
75/61	78.5 (267,700)	66.0 (225,100)	75.9 (259,000)	64.9 (221,300)	88.5 (302,000)	70.6 (240,800)
72/60	77.2 (263,400)	60.2 (205,400)	74.6 (254,700)	59.1 (201,500)	86.8 (296,400)	64.7 (220,800)
75/62.5	81.1 (276,800)	61.6 (210,300)	78.5 (267,800)	60.5 (206,400)	91.4 (311,800)	66.1 (225,700)
80/67	87.7 (299,300)	64.0 (218,300)	84.9 (289,700)	62.9 (214,600)	98.8 (337,200)	68.5 (233,900)

GFX-106XX @ 12000 CFM						
	Air Cooled		Glycol Cooled		Water Cooled	
EAT °F (DB/WB)	Net Total kW (BTU/hr)	Net Sensible kW (BTU/hr)	Net Total kW (BTU/hr)	Net Sensible kW (BTU/hr)	Net Total kW (BTU/hr)	Net Sensible kW (BTU/hr)
72/58.6	87.2 (297,700)	77.8 (265,600)	84.1 (287,100)	76.4 (260,800)	98.6 (336,500)	83.1 (283,500)
75/61	91.7 (312,900)	80.6 (274,900)	88.3 (301,300)	79.1 (269,900)	102.8 (350,800)	85.5 (291,700)
72/60	90.0 (307,000)	72.9 (248,900)	86.8 (296,100)	71.5 (244,100)	101.3 (345,600)	78.0 (266,300)
75/62.5	94.7 (323,000)	74.8 (255,300)	91.3 (311,600)	73.4 (250,600)	106.3 (362,700)	79.8 (272,300)
80/67	102.5 (349,900)	78.0 (266,000)	98.9 (337,500)	76.6 (261,200)	114.6 (391,200)	82.7 (282,300)



**GFX-XXXX @ STANDARD AIRFLOW**

Capacity, kW	Standard EC Plug Fans			Standard Cabinet Dimensions		
	Number of Fans	Standard Fan Size, mm	Standard Fan Motor, kW	Depth, in.	Length, in.	Height, in.
21	1	450	1.0	40.5	72.5	78.0
28	1	500	2.7	40.5	72.5	78.0
35	1	500	2.7	40.5	72.5	78.0
46	1	560	3.0	40.5	72.5	78.0
56	2	500	2.7	40.5	100.0	78.0
70	2	500	2.7	40.5	100.0	78.0
91	2	500	2.7	40.5	100.0	78.0
106	3	500	2.7	40.5	130.0	78.0

1. Performance data is based on ACFM and tested in compliance with ASHRAE Standard 127-2007 Standard Rating Conditions.
2. DOE certification reports and compliance statements for Data Aire products can be found under The Compliance Certification Database at <https://www.regulations.doe.gov/certification-data/>
3. Net capacity data includes fan motor heat.
4. Consult factory for alternate operating conditions or options as these may impact unit performance.

www.DataAire.com  
800-347-2473 | sales@DataAire.com  
230 W. Blueridge Avenue  
Orange, CA 92865



A member of the  
C/S Group of Companies  
Making Building Better®